

HID115X Incremental Encoder



Main Features

- Up to 3600 PPR
- Highly interference-resistant when used with frequency converters
- Robust and economical encoder with small dimensions
Maximum mechanical and electrical safety
- High noise immunity
- With control output
- Execrable environment
- Tacho flange
- With shaft $\Phi 8...12\text{mm}$
- Industrial standard encoder
- Protection IP65

Electrical Data

Resolution	1...1200PPR, 2000, 2500, 3600 PPR (Frequency response 125KHz)
Output circuit model	Difference line driver TTL/HTL (not adapted to Connector 7 pin) Complementary Voltage Open collector
Voltage supply	Line driver 26LS31 TTL: DC5V \pm 0.25 Line driver 26ET31 HTL: DC10...30V Complementary: DC5V,DC10...30V Voltage/ Open collector: DC5V, DC10...30V
Current consumptions	Line driver(TTL,HTL): 150mA Complementary: 60mA Voltage/ Open collector: 60mA
Output frequency	100 KHz
Load current	Line driver(TTL,HTL): 20mA Complementary: 30mA Voltage/ Open collector: 30mA
High level signal	Line driver TTL: 2.5V Line driver HTL: VccX70% Complementary: VccX70% Voltage/ Open collector: VccX70%
Low level signal	Line driver: 0.5V Complementary: 1V Voltage/ Open collector: 0.5V
Rise/fall time t_r / t_f	Line driver: 100ns Complementary: 1us Voltage/ Open collector: 1us
EMC	DIN EN 61000-6-2 DIN EN 55011

Mechanical Data

Max. rotational speed	6000r/min
Axial shaft load	50N
Radial shaft load	30N
Weight	500g (Without cable)
Starting torque(25°C)	5X10 ⁻² N.m
Bearing life	10 ⁹ RPM
Protection	IP65,shaft IP54
Material	Bearing: Stainless steel Housing: Cast aluminum Main body: Aluminum alloy
Connection	Cable axial / radial, Connector 7 pin axial / radial, Connector 12 pin axial / radial

Environmental Data

Operating temperature	-10°C ... 70°C
Storage temperature	-20°C ... 80°C
Humidity	98% RH
Shock	1000m/s ² , 6ms
Vibration	100m/s ² , 10 ... 200Hz

Output Circuit

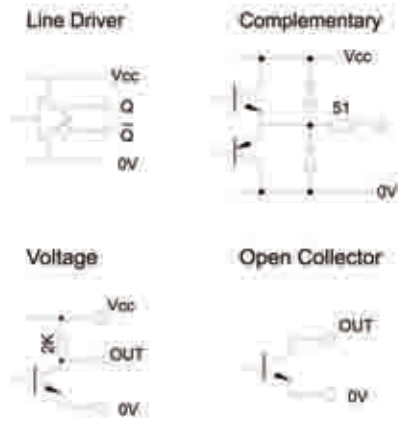

Output Signals

Track A,B,N

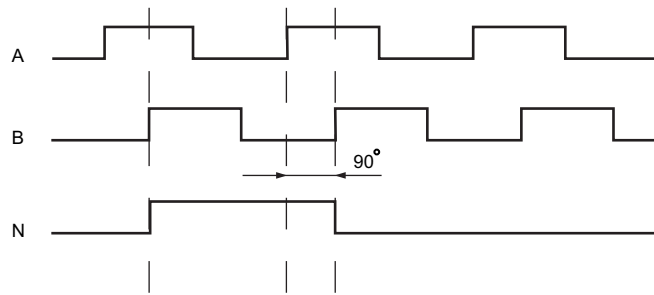

Track A,B,N and inv.

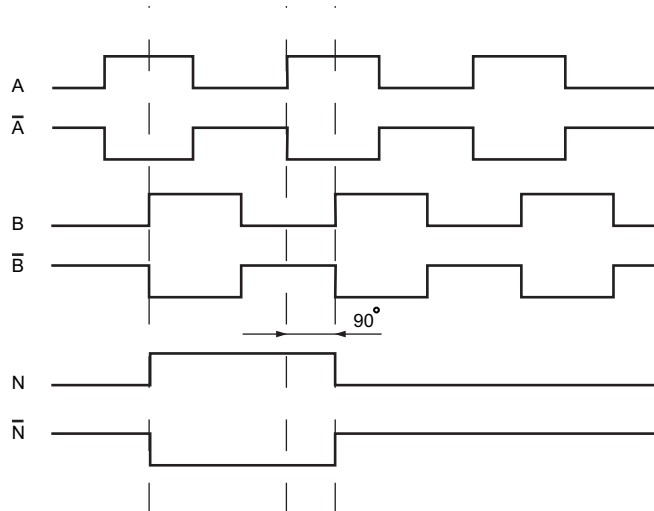

Connection diagrams

Cable Color	Cable	Connector 7 pin	Connector 12 pin
Brown	Vcc	Vcc Pin 2	Vcc Pin 12
White	0V	0V Pin 1	0V Pin 10
Green	A	A Pin 3	A Pin 5
Yellow	B	B Pin 4	B Pin 8
Gray	N	N Pin 5	N Pin 3
Red	\bar{A}		\bar{A} Pin 6
Black	\bar{B}		\bar{B} Pin 1
Purple	\bar{N}		\bar{N} Pin 4

Dimensions

Cable axial / radial:

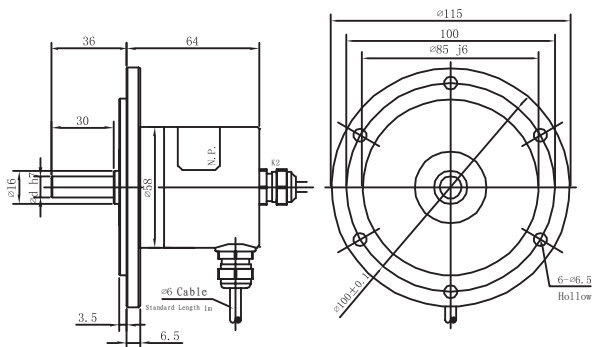

Connector 7 pin axial / radial:

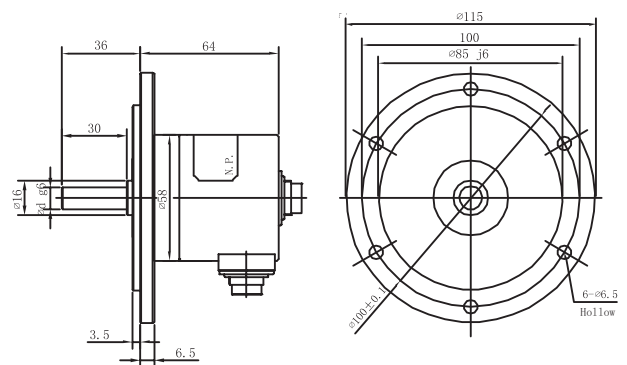

Connector 12 pin axial / radial:

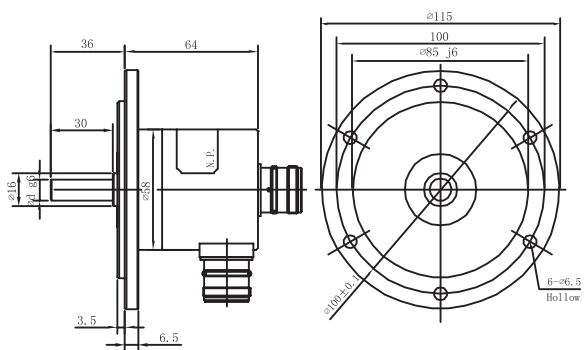

Ordering Information

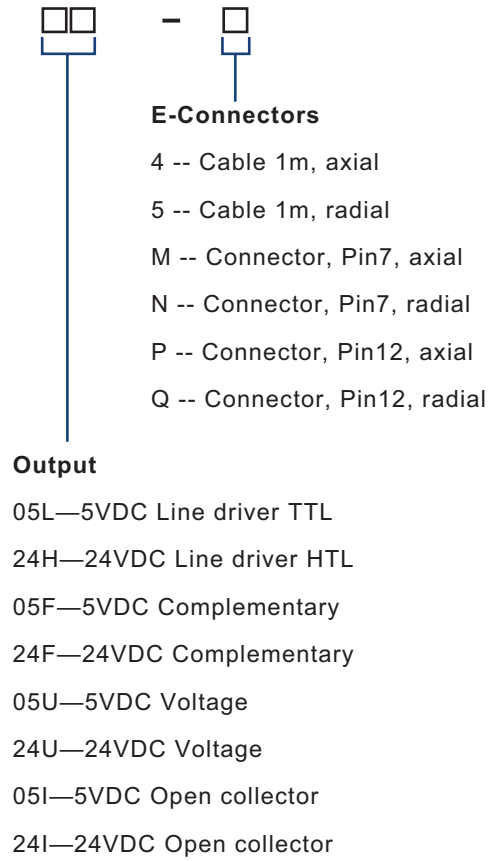
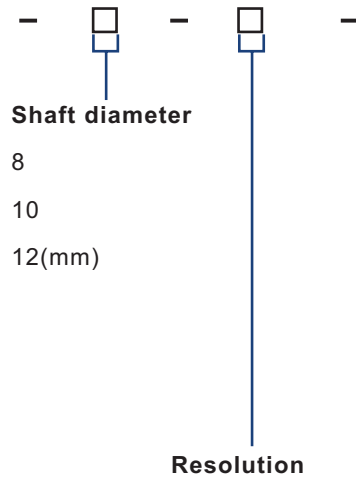
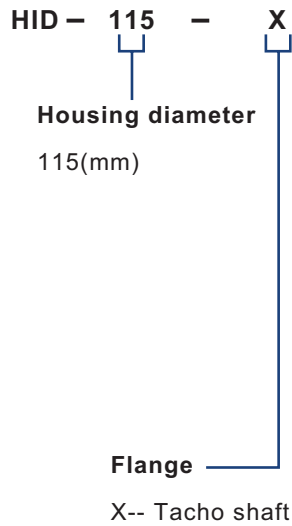

Resolution

50 (5)	58 (128)	23 (1000)	31 (2500)
37 (10)	07 (200)	24 (1024)	32 (3600)
51 (25)	10 (250)	25 (1250)	
40 (50)	14 (360)	27 (1500)	
41 (60)	15 (400)	29 (2000)	
42 (100)	16 (500)	30 (2048)	

Example: Ordering key 58 = 128 pulses.
Other pulse numbers on request.